

For International Students

Japanese STEP UP Course

Guide enables you to use Japanese, not just to understand

13 Online Courses from Beginner to Advanced

Small Groups
Online

<Course Examples>

- Learn Japanese for the first time Conversation for Beginner
- Always use "desu/ masu" when you speak Japanese Japanese Communication
- Want to convey my opinions in Japanese Speech & Discussion Primer
- Want to train honorific for job hunting Honorific Training I
- Want to pass the JLPT exam JLPT(N3~N1) Preparation Course
- Want to use the correct grammar Grammar for everyone
- Express myself well Speak Confident Japanese I

Course Period : 9th May ~ 15th Jul, 2022
 Number of Lessons : 10 times in total (Once a week × 10 weeks)
 Application Period : Friday 1st ~ Sunday 24th April

Enrollment is on a first-come-first-served basis.

The application will be closed once the total capacity is reached.

Applicable Courses : All courses * It might be changed.
 Course Fees : 8,000 yen/ course * Application up to 2 courses
 How to apply : From the URL below
 How to apply : <https://forms.gle/JNt8oNMWymRWpWvz5>



All applicants are required to take the preliminary consultation within the application period.

*Those who cannot attend live-streamed lessons or lessons during the course period cannot apply.

*The certificate of completion will be given if the participants completed the course with more than 90% attendance.



Group Lessons

Application up to 2 courses

90 mins × 10 times. Less than 10 students. The class will not be held if the applicants

Conversation

Please see Appendix 1 in the course guide for your CEFR level

Course No.	SG-1	Level	Zero - A1
Course	Conversation for beginner		
Course Description	This is a conversation class for those who are studying Japanese for the first time. Let's have fun studying while learning Japanese life and culture, focusing on "listening and speaking".		
Lesson Examples	<ul style="list-style-type: none"> • Talk briefly about your family • Visit / Welcome a friend • Talk about your favorite foods • Talk about your daily routine 		
Materials Plan	『まるごと』入門A 1 りかい		
Course No.	SG-2	Level	A1 - A2 (CEFR) Those who are not good at colloquial language.
Course	Communication in Japanese		
Course Description	Do you always use "desu / masu" when you speak Japanese? What do you say after greeting someone? What do you say when you talk to someone who looks busy? In this course, you will learn various conversational expressions according to the person and situation given. You will also enjoy communicating in Japanese by performing role-plays of various situations in university life and daily life.		
Lesson Examples	<ul style="list-style-type: none"> • How to keep the conversation after exchanging greetings. • How to skillfully extend invitation or make requests. • How to use the expressions that show you relate with the other person's story. 		
Materials Plan	Original Materials		
Course No.	SG-3	Level	A2 - B1 (CEFR) Those who are not good at public speaking, and who cannot express their opinions well.
Course	Speech & Discussion Primer		
Course Description	This course is designed to learn patterns when giving a speech, discussion, and debate for "people who are not good at public speaking" and "people who cannot express their opinions well". By learning the patterns, you can convey your opinions to the other person in an easy-to-understand manner. Also, by practicing speaking every time, you will be able to have confidence in speaking Japanese. You can also increase the vocabulary for each topic. *Assignments are given every time.		
Lesson Examples	<ul style="list-style-type: none"> • Speech on familiar topics • Discussion • Practice of expressions necessary for debate. → Have a discussion and a small debate. 		
Materials Plan	Original Materials		
Course No.	SG-5	Level	B2 - C2 (CEFR) Those who want to talk about something a little more advanced and complex.
Course	Speech & Discussion Advanced		
Course Description	This course is a practical speech course for advanced Japanese speakers. After learning the composition, Japanese expression, speaking style, and nonverbal communication, we will repeat the speech practice and aim for further improvement. You will also have the opportunity to present your achievements of speeches and presentations at the events, so please try to join it.		
Lesson Examples	<ul style="list-style-type: none"> • Speech on culture and society • Discuss the problems that you noticed from the content of the speech. 		
Materials Plan	Original Materials		

Business・Job Hunting

Please see Appendix 1 in the course guide for your CEFR level

Course No.	SG-6	Level	A2 - B2 (CEFR) Those who want to practice the usage of honorifics.
Course	Honorific Training I	Materials Plan	『新・にほんご敬語トレーニング』
Course Description	This course is for people who want to practice and use the honorifics used in the company. You will understand and practice the sentence patterns and expressions of honorifics based on conversations done in the business scenes by performing shadowing or role play. Those who will take "Honorifics Training I" also be able to take "Honorifics Training II" scheduled for this fall semester. *Will use the same textbook for I and II. *The textbook must be purchased.		
Lesson Examples	<ul style="list-style-type: none"> Understand and practice the proper use of honorific and humble words. You can change the wording depending on the person you request and the content. You can politely refuse to your superiors 		

Course No.	SG-7	Level	N1
Course	Practical Job-Hunting Japanese	Materials Plan	Original Materials
Course Description	The first half will mainly focus on group discussions. Practice on different patterns of themes and practice to concisely present the conclusions drawn by the team. In the second half, we aim to strengthen your speaking ability in preparation for the interview while deepening our understanding of ourselves and society.		

Course No.	SG-8	Level	N1
Course	Advanced Business Communication	Materials Plan	『ビジネスコミュニケーションのためのケース学習 2』
Course Description	Learn business communication while deepening cross-cultural understanding to address the issues of disagreement and conflict that arise when working with various people in global situations. Also, this course aims to strengthen your speaking ability by holding discussions and presentations every time. *The textbook must be purchased.		

JLPT Preparation

These classes specialize in JLPT preparation.
Please apply for a class of the level you plan to take.

Course No.	SG-10	Level	N4
Course	N3 Preparation(Grammar/ Vocabulary)	Materials Plan	『N3 文法スピードマスター』
Course Description	This course is for people who are aiming to pass N3 by mainly studying grammar. You can deepen your understanding of grammar by examining and using many examples of sentences used in everyday situations. Also, you can acquire the vocabulary by doing the task every week. *The textbook must be purchased.		

Course No.	SG-11	Level	N3
Course	N2 Preparation(Grammar)	Materials Plan	Original Materials
Course Description	This course is for people who have never studied N2 grammar or have studied grammar by themselves but do not understand the difference in grammar usage. Understand the usage of grammar and deepen your understanding of similar grammar differences.		

Course No.	SG-12	Level	N3
Course	N2 Preparation (Reading/Listening)	Materials Plan	『日本語能力試験 N2 読解 必修パターン』
Course Description	This course is for people who are not good at "reading/listening comprehension" in the JLPT test. You will be given commentary and tips for each area of study. You will also deepen your understanding by solving many problems. *The textbook must be purchased.		

Course No.	SG-13	Level	N2
Course	N1 Preparation (Language Knowledge/Reading)	Materials Plan	『JLPT 日本語能力試験ベスト模試 N1』
Course Description	This course focuses on grammar, vocabulary, and reading comprehension exercises for N2 level students who have not yet passed the N1 of the Japanese Language Proficiency Test. It also considers how to solve questions. * Although it is intended for N2 level students, students who have passed the N1 exam with a score of 110 points or less and want to study more can also apply. The teacher will assess your proficiency in the preliminary consultation and decide whether or not it is necessary to attend. *The textbook must be purchased.		

Grammar・Expression

Course No.	SG-14	Level	N2
Course	Grammar for everyone	Materials Plan	Original Materials
Course Description	Have you ever experienced being worried about not having the basic Japanese skills? Even when you entered university or being in the 3rd or 4th grade, you still don't have enough Japanese ability and committing many grammatical mistakes. This course has been prepared for you who haven't yet mastered the fundamentals. Check your problems carefully and overcome your weak points in this course.		
Course No.	SG-15	Level	N3～N1
Course	Speak Confident Japanese I	Materials Plan	『日本語文法ブラッシュアップトレーニング』
Course Description	The purpose of this course is to learn accurate grammar and to be able to output Japanese with confidence. You can learn that using the wrong grammar has different meanings, and practice expressing it correctly with the correct grammar. You will do casual speech in each lesson so that you can enjoy talking Japanese with confidence. * In the fall semester of this academic year, we plan to have "Speak Confident Japanese II" using the same textbook this spring semester. *The textbook must be purchased.		

Course Level

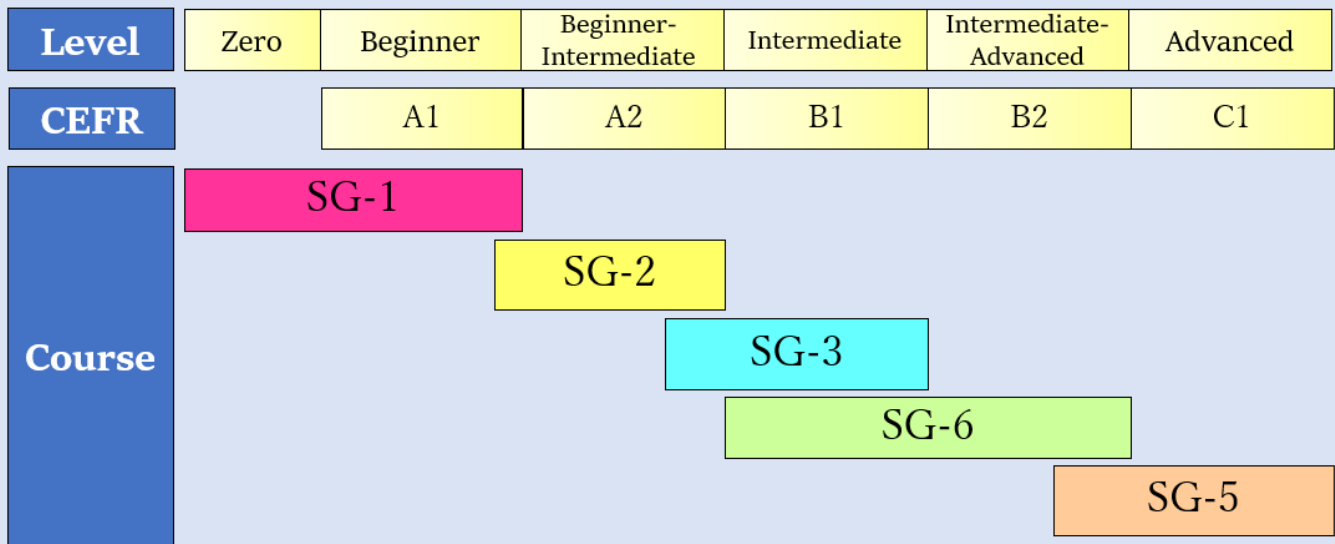

More details are from here.

▶ [Toyo University Japanese](#)



▶ [Toyo University Global Service Co., Ltd](#)



Students' voices are from here.



I have learned to interpret intonation in conversational Japanese. Throughout this course, I also get to practice some common phrases to use in daily life as well as how to communicate in Japanese.



I have learned quite a lot in the course. The instructor was able to take us through the course in a way I could understand. My Japanese language has improved as compared before starting the course. I was able to communicate a little with friends.



東洋大学日本語講座 / TOYO UNIVERSITY JAPANESE PROGRAM

電話: 03-3945-4263 Email: ml-lc@toyo.jp

CEFR self-assessment grid

Spoken Interaction

Spoken Production

C1

I can express myself fluently and spontaneously without much obvious searching for expressions. I can use language flexibly and effectively for social and professional purposes. I can formulate ideas and opinions with precision and relate my contribution skillfully to those of other speakers.

I can present clear, detailed descriptions of complex subjects integrating sub-themes, developing particular points and rounding off with an appropriate conclusion.

B2

I can interact with a degree of fluency and spontaneity that makes regular interaction with native speakers quite possible. I can take an active part in discussion in familiar contexts, accounting for and sustaining my views.

I can present clear, detailed descriptions on a wide range of subjects related to my field of interest. I can explain a viewpoint on a topical issue giving the advantages and disadvantages of various options.

B1

I can deal with most situations likely to arise whilst travelling in an area where the language is spoken. I can enter unprepared into conversation on topics that are familiar, of personal interest or pertinent to everyday life (e.g. family, hobbies, work, travel and current events).

I can connect phrases in a simple way in order to describe experiences and events, my dreams, hopes and ambitions. I can briefly give reasons and explanations for opinions and plans. I can narrate a story or relate the plot of a book or film and describe my reactions.

A2

I can communicate in simple and routine tasks requiring a simple and direct exchange of information on familiar topics and activities. I can handle very short social exchanges, even though I can't usually understand enough to keep the conversation going myself.

I can use a series of phrases and sentences to describe in simple terms my family and other people, living conditions, my educational background and my present or most recent job.

A1

I can interact in a simple way provided the other person is prepared to repeat or rephrase things at a slower rate of speech and help me formulate what I'm trying to say. I can ask and answer simple questions in areas of immediate need or on very familiar topics.

I can use simple phrases and sentences to describe where I live and people I know.